



# Winding resistance measurement on power transformers

# Information





Author      Santiago González

TI-52

# Table of Content

Foreword .....	3
Basics.....	3
Current stability .....	4
Transformer core saturation.....	4
Windings overheating.....	5
Test Current selection .....	5
Discharging .....	6
Safety considerations.....	6
Delta windings .....	6
Experimental Results Delta Winding.....	7
Flux optimized YND method .....	8
Experimental Results Flux Optimized .....	8
Transformer Connection .....	9
References.....	9
Notes .....	10

## icon key

	Valuable information
	Important note
	Technical explanation
	Workbook review

## Foreword

Winding resistance measurement is defined as routine test in the IEC 60076 and ANSI standard for all manufactured power transformers. Result of the test is used for both load losses calculation during load losses test and temperature calculation during the Heat run test.

In addition, winding resistance measurement is an accepted test worldwide for predictive maintenance on power transformers, due to its ability to detect connection or contact errors, overheated connections or tap changer problems.

Due to above reasons, an accurate measurement is of maximum importance, but Measurement of winding resistance of large power transformers faces several difficulties. Long charging and discharging times, fluctuating values when measuring closed delta winding systems due to long stabilization times, inaccurate temperature measurements for resistance correction, residual magnetism and its adverse effects, inefficient connection and disconnection of the measuring equipment are just some of the difficulties to be dealt with.

In the following chapters we will provide the basics about this test, as well as some solutions to the problems arising while performing the measurement.

## Basics

A power transformer winding is manufactured by winding a conductor, normally copper or aluminum, around a magnetic core.

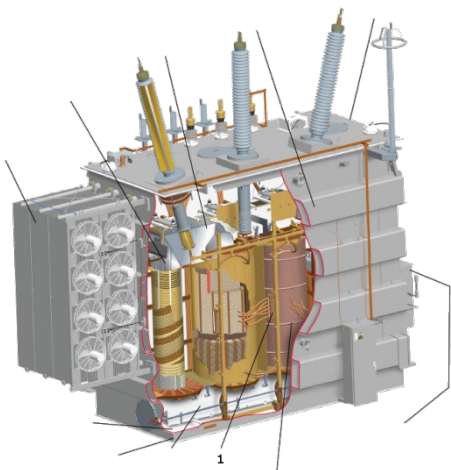

Figure 1 Power transformer cut away

This coil will have, at normal main frequencies, an inductance (depending on the number of turns and coil length) and a resistance (depending on conductor section, material and length).

$$L = \frac{\mu AN^2}{l}$$

$$R = \rho \frac{l}{A}$$

$\mu$	Magnetic permeability
$A$	Cross-sectional area
$N$	Number of turns
$l$	length
$\sigma$	Material resistivity

Both parameters are physically linked, but the aim of the test is to separate them. Therefore a way to eliminate the inductive part has to be found.

An inductor, while applying a DC current through a resistor, store part of the energy applied in the form of a magnetic field. The time required to store the energy (Charge the inductor) depends on the inductor and resistance value and is known as time constant ( $\tau = L/R$ ).

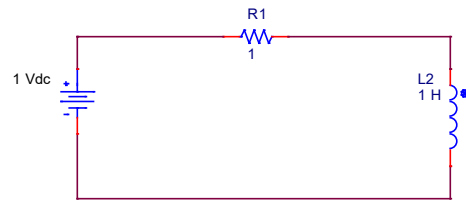

Figure 2 - L-R circuit

$$i_L(t) = I_0 e^{-\frac{R}{L}t}$$

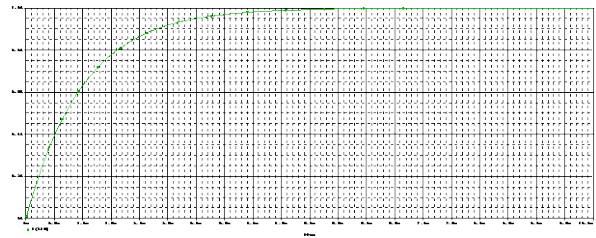

Figure 3 Current in function of time in an inductor under DC

Once the inductor is fully charged act as a short circuit and the circulating current is only limited by the resistance, under this situation (time long enough) the resistor can be easily measured.

$$R = \frac{U}{I} = \frac{U_R + U_{LM}}{I} = \frac{U_R}{I} + L_M \cdot \frac{dI}{dt}$$

$$R_{t \rightarrow \infty} = \frac{V_{dc}}{I_0}$$

This inductance in power transformers is rather large, typically in the range of 0.1H to 5000H. Therefore time constant, dependent on the inductance, become also long.

The accuracy of the reading will also depend on the number of time constants, and only when reached 10 time constants ( $\tau = L/R$ ), accuracys above 0.1% can be reached.



By using direct current, we have found a way to separate the resistance of the inductance in an inductor which are physically linked, therefore DC has to be used while measuring resistance in a transformer winding.

### Current stability

It is common practice to use off-the-shelf power supplies to supply the measuring current to the transformer. The feedback current control loop of such devices is not designed for high inductive loads. Therefore the output voltage of these devices oscillates depending on the load. Figure 4 shows a case with a damped oscillation, where the supply takes a long time to stabilize.

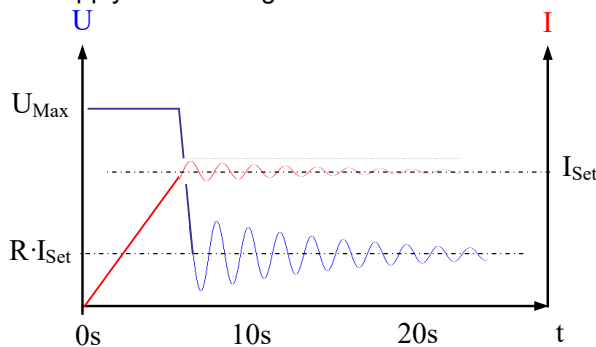

Figure 4 Transient oscillation of a power supply in constant current mode with a highly inductive load

The oscillation (or ripple) is a change of current in function of time, which generates a voltage in the inductor and introduces an error in the resistance value measured in the best case, or generates non -stable readings under some circumstances.



Increasing the measurement current over the saturation level leads to a much lower magnetizing inductivity. This lower inductivity helps the standard power supply to stabilize. This is one reason why testing engineers often believe, that a high measurement current is necessary to get fast stabilization.

### Transformer core saturation

The material used in the manufacturing of the power transformer core, normally grain oriented steel, is not linear, following the known b-h curve.

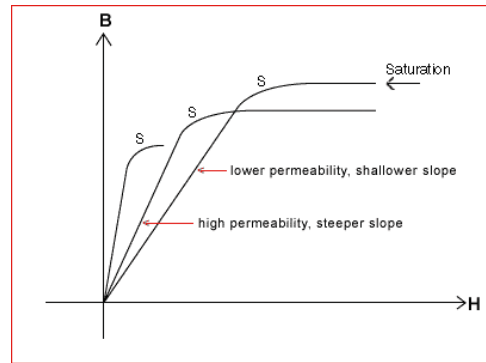

The relative permeability is dependent on the magnetic field, once magnetic field reach saturation, the permeability drops drastically. the inductance drop in the same magnitude as the relative permeability.

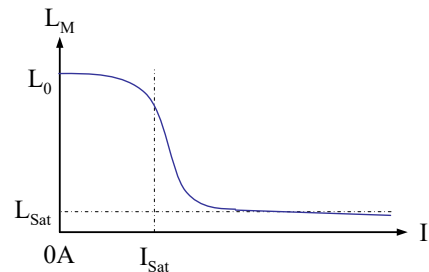

The necessary time to saturate the inductor, and therefore being able to measure only the resistor, depend on the inductance value, as higher the inductor, as longer the time. By

saturating the transformer core, the required time to get stable results is reduced.

Saturation of the transformer core appears once the necessary magnetic flux density is reached, in standard grain oriented steel this is in the range of 1.4 to 2 Tesla. The magnetic flux density will depend, among others, on the magnetic flux, the surface area of one turn and the number of turns.

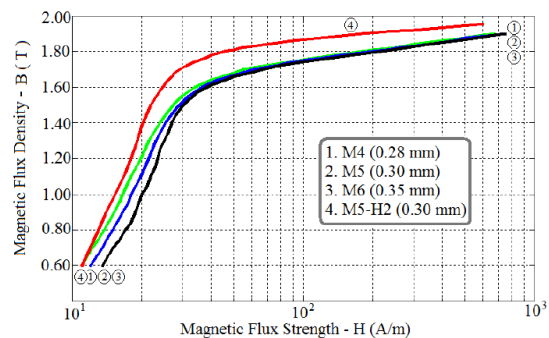

Figure 4 Permeability of magnetic materials

Both the number of turns and the surface area are fixed by the winding and core construction, therefore the only parameter that we can influence to saturate the core is the magnetic flux, which is dependent on the voltage applied and the time during it is applied.

$$B(t) = \frac{1}{A * N} \int_0^t V(t) dt$$

B	Magnetic flux density (Testla)
A	Area
N	Number of turns
V	Voltage

A fast calculation of the magnetic flux required to saturate the core, assuming that the saturation will happen slightly above the peak value of the nominal transformer voltage, can be done by integrating the sinusoidal wave during one fourth of a cycle. For a 420kV transformer at 50 Hz would be 1890 V x sec.

On power transformers, a common value of the necessary magnetic flux would be in the range of several hundreds of volts \* second (200 ... 4000).

If a current power supply, necessary to stabilize the current and measure the resistor, is connected to an R-L circuit, the inductor will at the beginning limit the current and get all the available voltage, the increase of the flux, as explained before, will mostly depends on the maximum output voltage, and will be faster with higher voltages.

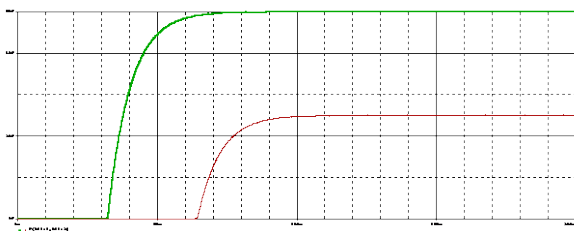

Figure 5 Voltage drop in Resistor R1 with 50V (red) and 100V (green)

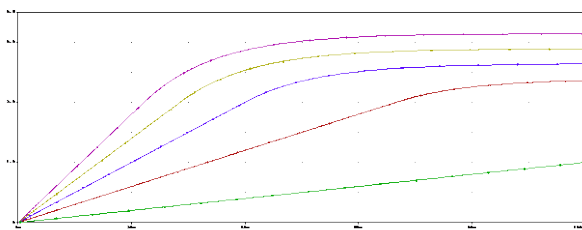

Figure 6 Flux in Core at different voltages

It can be established that to reduce the time required to saturate the core of a high voltage winding, a larger test voltage is required, opposite to the accepted understanding that higher currents saturates the core faster.

## Windings overheating

The resistance of a given material depends primarily on three factors. What material is made of, its cross sectional area and the length.

$$R = \sigma \frac{l}{A}$$

$\sigma$	Material resistivity (1.724 x 10 <sup>8</sup> Ohm/m) for copper
A	Cross-sectional area
l	length

In conductive materials, like copper, the resistivity is not constant and depends on temperature by the temperature coefficient of resistance, at higher temperatures higher resistances.

$$R = R_0(1 + \alpha(t - t_0))$$

R	Resistance at initial temperature
$\alpha$	Temperature coefficient of resistance
$t_0$	Initial temperature
t	Final temperature

While circulating a fix current trough a conductor like copper, the power generated is mostly converted into heat, this self-generated heat increases the temperature of the conductor, increasing its resistance, and increasing the self-generated heat.

This never end situation reach stabilization when the heat generated and dissipated stabilizes.

To avoid unstable readings, the current introduced should be small enough that the temperature increase is much slower than measuring time.



The standards, reflecting the problem, require DC measuring currents below 15% (ANSI) or 10% (IEC) of the nominal winding current.

## Test Current selection

Because of the large magnetizing inductivity of the transformer, the measuring current cannot be applied instantaneously. The current can only change according to equation

$$\frac{dI}{dt} = \frac{U_{LM}}{L_m}$$

For a given transformer (given inductance), the rate of change of the measuring current depends



only on the voltage applied to the magnetizing inductivity  $L_m$ . Current charging and discharging time depends mainly on the maximally available supply voltage.

In order to reach saturation, final (target) measuring current should be above saturation current, which can be normally expressed in terms of the no load current  $I_0$ .

$$i \approx 1.5 \times I_{0,RMS}$$

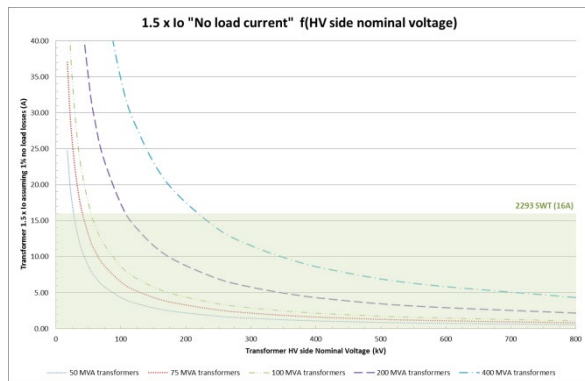

it can be establish then, that the test current while measuring winding resistance should be.

1. Large enough to reach saturation, which is normally higher than the peak value of the no load losses current. As role of thumb we can fix 1.5 to 2 times the no load losses current, this current is rarely above 15A.
2. Small enough to avoid winding heating, means below 10% of the nominal winding current.

### Discharging

While applying direct current to an inductive test object, it will store energy which has to be dissipated at the completion of the measurement.

$$W = \frac{1}{2} LI^2$$

The discharging time can be as long as the charging time depending on the discharging circuit, active discharging circuits are required to reduce the discharging time and therefore the overall measuring time.

### Safety considerations

If the current is suddenly interrupted during the measurement. High voltages will arise in the measuring terminal which can damaged the device or even injury or kill the personal.

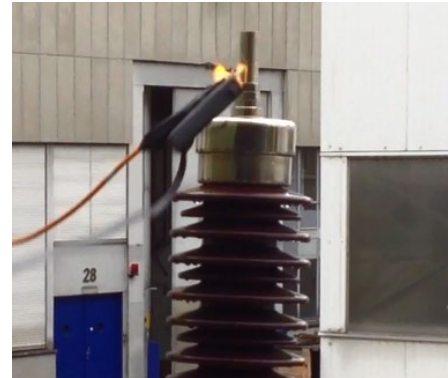

Instruments used for winding resistance measurement must be equipped with safety indicators.

1. Proper measuring clamps that can not be easily released during a test.
2. Discharging circuit to discharge the energy stored during the measurement, even if the instrument is unplugged.
3. Current circulation indication and safety status indicator informing when is safe to disconnect the clamps.

In addition, and as a normal safety role, the grounding stick must be used before touching any transformer terminal after a test.



One important observation during winding resistance measurement is that by stopping the measurement, or even pushing the safety switch, is not yet safe to touch the terminals as the discharging circuit have to remove the stored energy.

### Delta windings

Delta winding transformer has the characteristic that current circulates trough all phases even if only applied to one phase

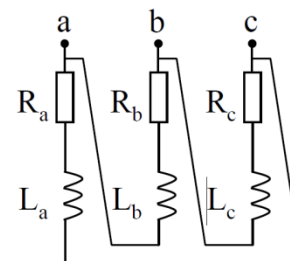

The electrical equivalent circuit while measuring winding resistance between terminals a to b would be.

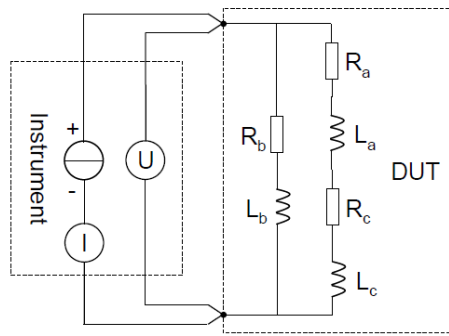

When applying a DC voltage between terminals 'a' and 'b', current starts to flow between the two depicted branches. Simultaneously a flux (voltage) is induced on each inductance.

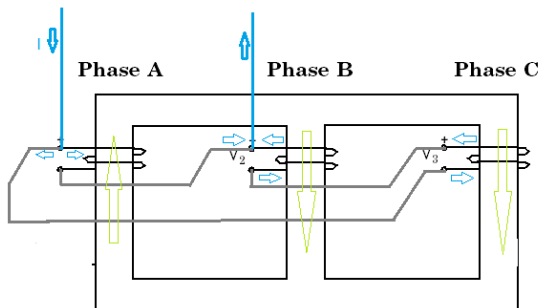

The inductance of the core can be calculated based in the geometry as

$$L_M = \frac{N^2}{R_M} = \frac{N^2 \mu A_{Fe}}{l_{Fe}}$$

As can be seen for a three phase transformer, the core length (magnetic path) of all phases is not the same, being the same for the outer limbs, and smaller for the middle limb.

$$L_A \cong L_C \neq L_B$$

When The saturation current is reached, the current is balanced in the circuit by the windings inductances

$$\frac{I_B}{I_A} = \frac{L_A + L_C}{L_B} \neq 2$$

But in steady state condition ( $di = 0$ ), the current distribution in both paths is given by the resistance ratio

$$\frac{I_B}{I_A} = \frac{R_A + R_C}{R_B} \cong 2$$

The time constant ( $\tau_B$ ) of the current balancing is an exponential process characterized by the

passive components involved. Which can be described as follows:

$$\tau_B = \frac{L_a + L_b + L_c}{R_a + R_b + R_c}$$

After  $5\tau$  The current imbalance has dropped to about 0.67%. After  $\tau$  The deviation to the steady state value is about 0.091%, and therefore the measured resistance has reached a reasonable accuracy.

When the delta winding is on the low voltage side of a large generator transformer, the winding resistance is typically very small ( $<10\text{m}\Omega$ ). According to equation (9), this leads to a large time constant for the circulating current to go to zero. Measurement stabilization times can be from several minutes up to one hour on large transformers.

### Experimental Results Delta Winding

Measurement on the following transformer was done.

YNd5 ; 50MVA; 225kV – 17.75 kV  
R = 10mOhm  
 $I_0 = 1\text{A} \rightarrow L_0 \cong 50\text{H}$

From *Figure 4 Permeability of magnetic materials*, a difference between the saturated and non-saturated permeability can be estimated in 300, therefore.

$$L_{SAT} \approx \frac{L_0}{300} \approx 167\text{mH}$$

$$7\tau = 7 * \frac{L_{SAT}}{R_B} \approx 117\text{s}$$

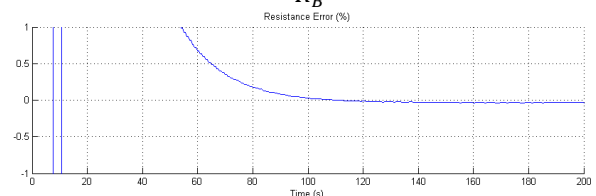

Figure 7 Winding resistance error in %

So, the theoretical result fits quite well the reality. Further we can observe, that for any current  $>2\text{A}$ , this measurement takes about 100 – 120 s. Tests were done for 2A, 5A, 10A, 20A, 33A and 50A.



### Flux optimized YND method

One way to speed up this stabilization time is to decrease the magnetizing inductivity of the transformer. This can only be done by saturating the transformer core. On low voltage windings of large power transformers, the saturation current can easily exceed 10A to 100A. Which is the reason why testing engineers often want to have high current (>50A) measuring devices. Other method is the flux optimized YND method described here.

The goal of this method is to reduce the magnetizing inductivity by saturating the core, too. But this method uses the high voltage winding to saturate the core, because the saturation current on the high voltage side can be significantly lower than on the low voltage side (depending on the turns ratio):

$$I_{Sat}^{HV} = I_{Sat}^{LV} \cdot \frac{N_2}{N_1} \quad (10)$$

Figure 7 shows the relative steady state flux distribution in the transformer core, when applying a current  $I_2$  from 'a' to 'b' on the transformer depicted in figure 5. Since the ratio of the currents  $I_b$  and  $I_a$  is about 2, also the ratio of the fluxes in the corresponding core legs is about 2.

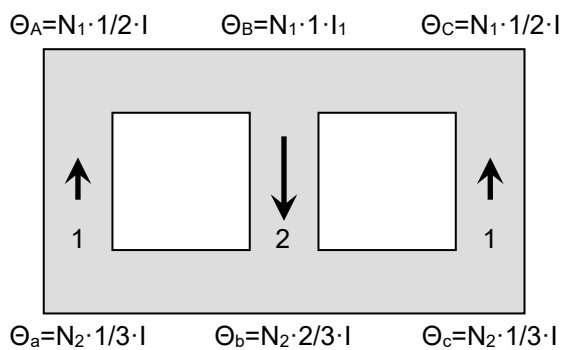

**Figure 7:** Flux distribution when measuring LV b-a

As already mentioned, the core gets saturated by injecting another current into the high voltage winding, which has many more turns ( $N_1$ ) than the low voltage winding ( $N_2$ ). The key point of the described method is that the flux distribution generated by the high voltage winding matches the flux distribution generated by the low voltage side. Figure 7 also show the electromotive forces  $\Theta$  generated by each winding, which indicate the current distribution in the windings.

A method to deal with the long stabilization times when measuring a low ohmic delta winding (e.g. large generator transformers) described can be used as long as a start with Neutral is available in the transformer, which is normally the case on step up transformers.

### Experimental Results Flux Optimized

Tests with the described method have been performed on an 1'100 MV generator transformer (YNd5, 27kV to 420kV step-up) to compare the performances of the different methods. The nominal resistances of the phases on the low voltage side are about 1.12mΩ. The saturation currents are  $I_{Sat1} \approx 0.9A$  and  $I_{Sat2} \approx 12A$  Figure 8 illustrates the stabilization time of the resistance reading, when supplying 8A to the low voltage winding only.

Figure 8 and figure 9 illustrates the stabilization time of the resistance reading, when the flux optimized YN-Delta method is used with 8A on the high voltage side and 8A on the low voltage side. In both cases the measurement current injected on low voltage side is 8A, which is smaller than the saturation current  $I_{Sat2} \approx 12A$ . But the stabilization time with the traditional method is much longer (25 to 30 minutes) than with the optimized method (6 to 14 minutes).

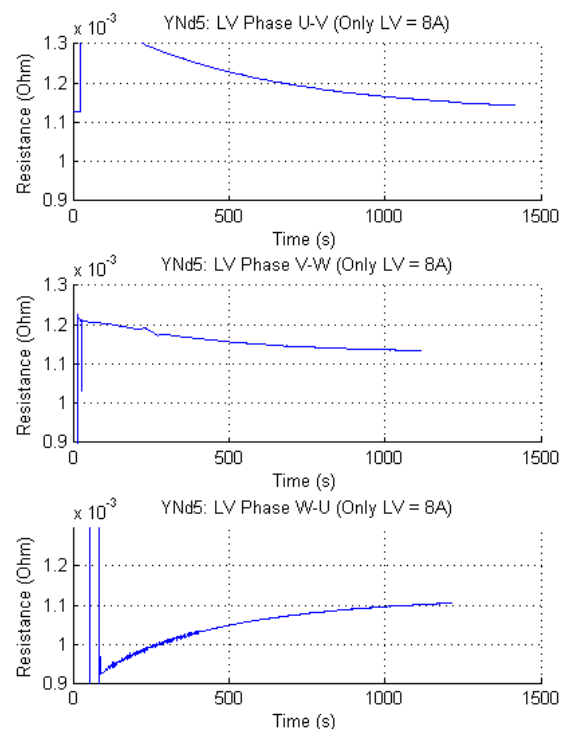

**Figure 8:** Resistance measurement on a large generator transformer (YNd5, 1100MVA) using the common method with  $I_2 = 8A$  (Only LV)



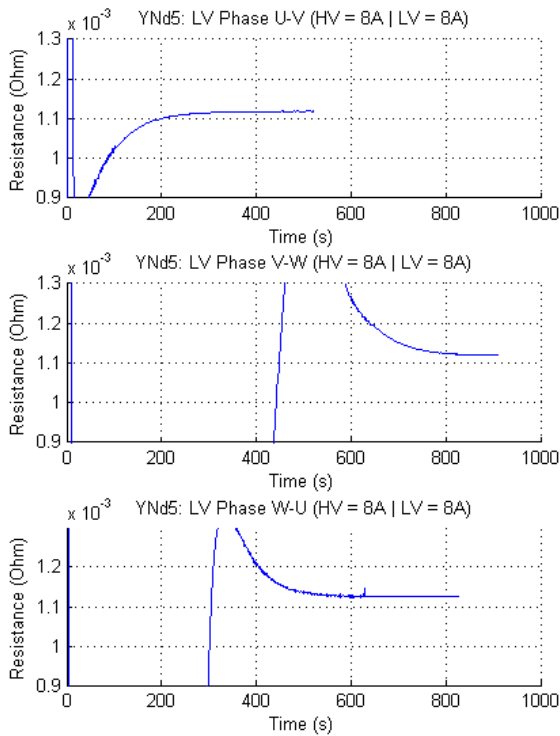

Figure 9: Resistance measurement on a large generator transformer (YNd5, 1100MVA) using the flux optimized YN-Delta method with  $I_1 = 8A$  (HV) and  $I_2 = 8A$  (LV)

### Transformer Connection

The connection of a traditional high current winding resistance measurement device with two channels and one current supply is depicted in figure 11.

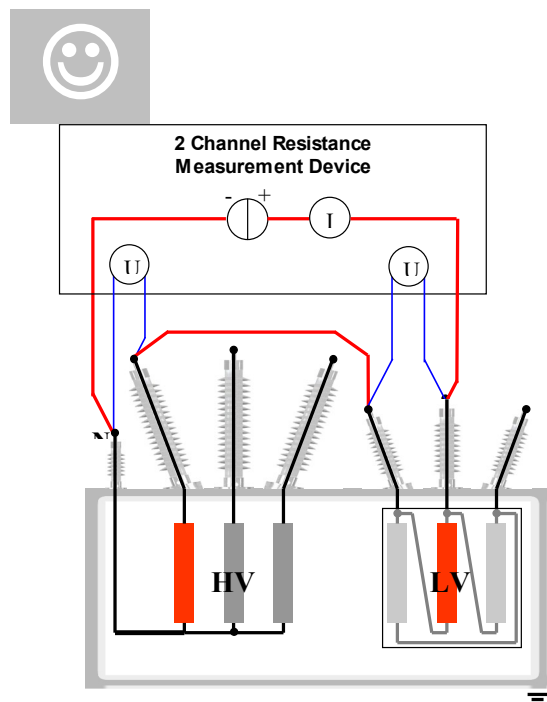

Figure 11 Traditional winding resistance measurement with two channels

A total of 7 cables are needed to perform this measurement: Two supply cables, one jumper cable and four sense cables to measure the voltage drop at the DUT.

In addition, with this method a maximum of two resistances can be measured before reconnect the DUT (One on the low voltage side and one on the high voltage side). More than that the user of the device has also to figure out the right way to connect the cables that fluxes generated are not opposite and delay the stabilization.

With a multichannel topology the user has to connect the DUT only once. As illustrated in Figure 8 2293 transformer connection, for each bushing on the transformer there is one special kelvin clamp (which inject the current and read the voltage). Thus, no reconnection is required to measure the complete transformer. This reduces the measuring time and the probability of a faulty connection.

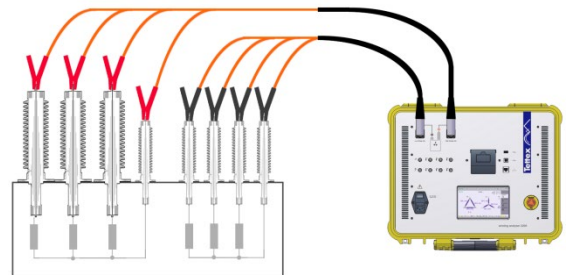

Figure 8 2293 transformer connection

Kelvin clamps have two electrically isolated jaws, each connected to a separate wire. This makes it possible to connect the complete transformer with only 8 Kelvin clamps and 8 cables.

### References

1. Optimized tool for the measurement of winding resistances on power transformers, Marc Muller.
2. IEC 60076.
3. Tettex 2293 Instruction manual.

S

**NOTES:**

## Global Presence

### Europe

HAEFELY AG  
Birsstrasse 300  
4052 Basel  
Switzerland

☎ + 41 61 373 4111  
✉ [sales@haefely.com](mailto:sales@haefely.com)

### China

HAEFELY AG Representative Office  
8-1-602, Fortune Street, No. 67  
Chaoyang Road, Beijing 100025  
China

☎ + 86 10 8578 8099  
✉ [sales@haefely.com.cn](mailto:sales@haefely.com.cn)

This document has been drawn up with the utmost care. We cannot, however, guarantee that it is entirely complete, correct or up to date. ©Copyright HAEFELY/ Subject to change without notice

V2020.10